

HULTDINS SuperGrip™

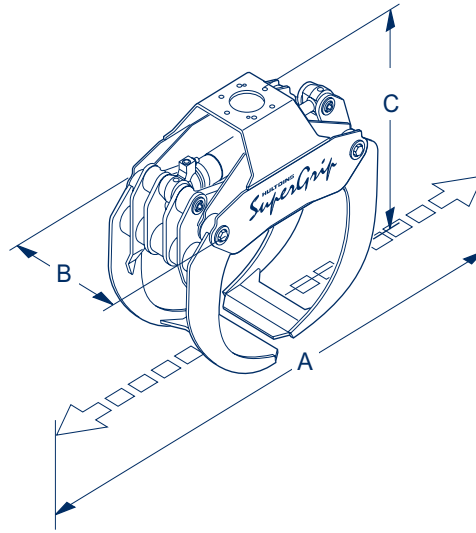

Features

- Tapered sleeve pin design eliminates any possible joint motion.
- Cushioned cylinders to reduce shock loads.
- Sealed bushings extend greasing intervals to 1000 hrs.
- Dual push rods for balanced design.
- Grapple saw option available on all models.

SuperGrip			260S		300S		360S		520S	
Weight	lb (kg)		506	(230)	515	(234)	814	(370)	924	(420)
Max. load	lb (kg)		7700	(3 500)	9900	(4500)	11000	(5 000)	15400	(7 000)
Gripping area, tip-tip	ft ² (m ²)		2.80	(0.26)	3.23	(0.30)	3.87	(0.36)	5.59	(0.52)
Gripping area, practical	ft ² (m ²)		3.77	(0.35)	4.31	(0.40)	4.84	(0.45)	6.67	(0.62)
Max. gripping width "A"	inches (mm)		60.0	(1 525)	58.3	(1 480)	73.6	(1 870)	91.4	(2 322)
Overall grapple width "B"	inches (mm)		17.0	(430)	17.0	(430)	20.5	(522)	20.2	(514)
Height, arms tip-tip "C"	inches (mm)		34.2	(867)	32.9	(836)	39.3	(998)	45.5	(1 155)
Max. height arms open	inches (mm)		29.9	(760)	31.7	(804)	31.5	(800)	34.9	(886)
Min. height arms closed	inches (mm)		21.7	(550)	22.0	(560)	25.8	(656)	29.4	(747)
Grapple jaw width	inches (mm)		15.4	(392)	15.1	(384)	18.1	(460)	19.0	(484)
Min. gripping diameter	inches (mm)		3.5	(90)	3.5	(90)	4.3	(110)	6.7	(170)
Volume capacity 8 ft wood	cords		0.23		0.27		0.30		0.42	
Gripping force, arms open, @ 3625 psi	lbf (kN)		2451	(10.9)	2451	(10.9)	4161	(18.5)	4701	(20.9)
Gripping force, arms tip-tip, @ 3625 psi	lbf (kN)		3396	(15.1)	3396	(15.1)	4319	(19.2)	5196	(23.1)
Opening time, at 50 l/min	s		0.9		0.9		1.6		2.2	
Closing time, at 50 l/min	s		1.7		1.7		2.6		3.7	
Max. operating pressure	psi (MPa)		3625	(25)	3625	(25)	3625	(25)	3625	(25)

0113-7000600-CAN



Hultdins Inc.
 22 Morton Avenue East, Brantford,
 Ontario, Canada N3R 7J7
 Ph (519) 754-0044, Fax (519) 754-1569
 E-mail: info@hultdins.com

www.hultdins.com
 With reservation for possible changes and any inaccuracies.

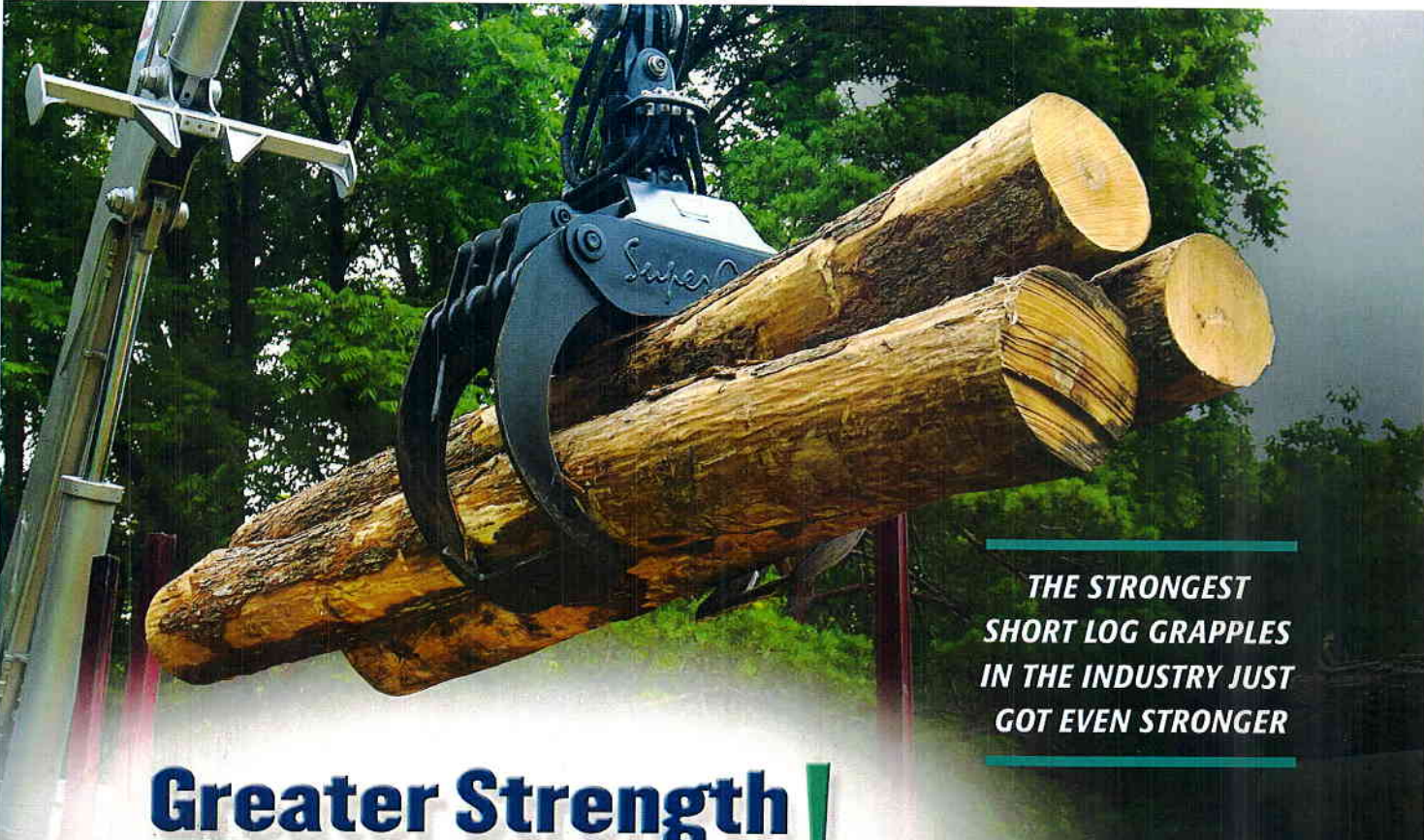

**THE STRONGEST
SHORT LOG GRAPPLES
IN THE INDUSTRY JUST
GOT EVEN STRONGER**

Greater Strength! Legendary Performance!



SOLID CAST STEEL Push Rod design sets the new **STANDARD FOR STRENGTH** on HeavyDuty "S" Models



FOR FORWARDERS AND LOG TRUCKS

- Over 30 years of grapple manufacturing experience - *proven in the forest*
- Robotic welded high strength construction throughout
- Cushioned cylinder for long term durability
- Available in a wide range of grapple sizes and boom mounts
- Patented tapered sleeve pin joints
- 1,000 hour greasing interval



See us on
You Tube

Get a **Firm Grip** on Productivity



Our strength is in the details