



» STRONG-ARM GRAPPLES

UTILITY LOADER BUNCHING GRAPPLE



SPECIFICATIONS

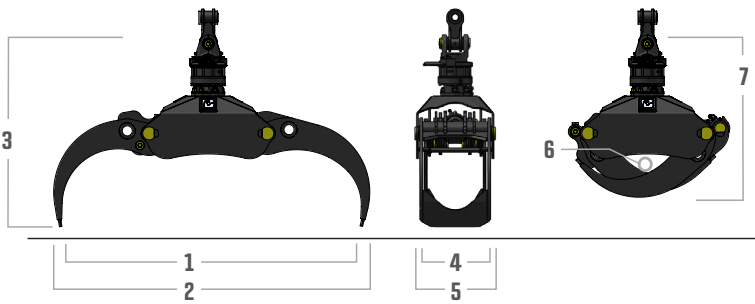

7422 GRAPPLE

	7422
DIMENSIONS	
1	Maximum Opening 74" (188 cm)
2	Width Open 78.7" (200 cm)
3	Height Open 45.5" (115 cm)
4	Tine Width 17.5" (44 cm)
5	Overall Width 19.9" (50 cm)
6	Minimum Closing 4.5" (114 mm)
7	Height Closed 38.2" (97 cm)
	Arm Steel Thickness 0.75" (19 mm)
	Weight 984 lbs (446 kg)

ROTATOR	
Lift Capacity	22,000 lbs (9,979 kg)
Torque at Maximum Operating Pressure	19,470 in-lbf at 3,625 psi (2,200 Nm at 250 bar)
Operating Pressure	2,000-3,625 psi (137-250 bar)
Speed at Recommended Flow	28 RPM
Maximum Flow	6.5 GPM (25 LPM)

CYLINDER	
Bore Diameter	3.5" (90 mm)
Pressure Range	2,000-3,625 psi (137-250 bar)
Carrier Flow Range	15-30 GPM (57-113 LPM)

MATERIALS	
Structural	High tensile, wear-resistant steel
Bushings	Bronze and steel
Finishes	Powder coating and zinc-plated pins



BARKO HYDRAULICS, LLC
One Banks Ave.
Superior, WI 54880

P: 715.395.6700
info@barko.com | www.barko.com



18 Months

WARRANTY

Full attachment with **UNLIMITED** hours